

Machine optional

PAPER

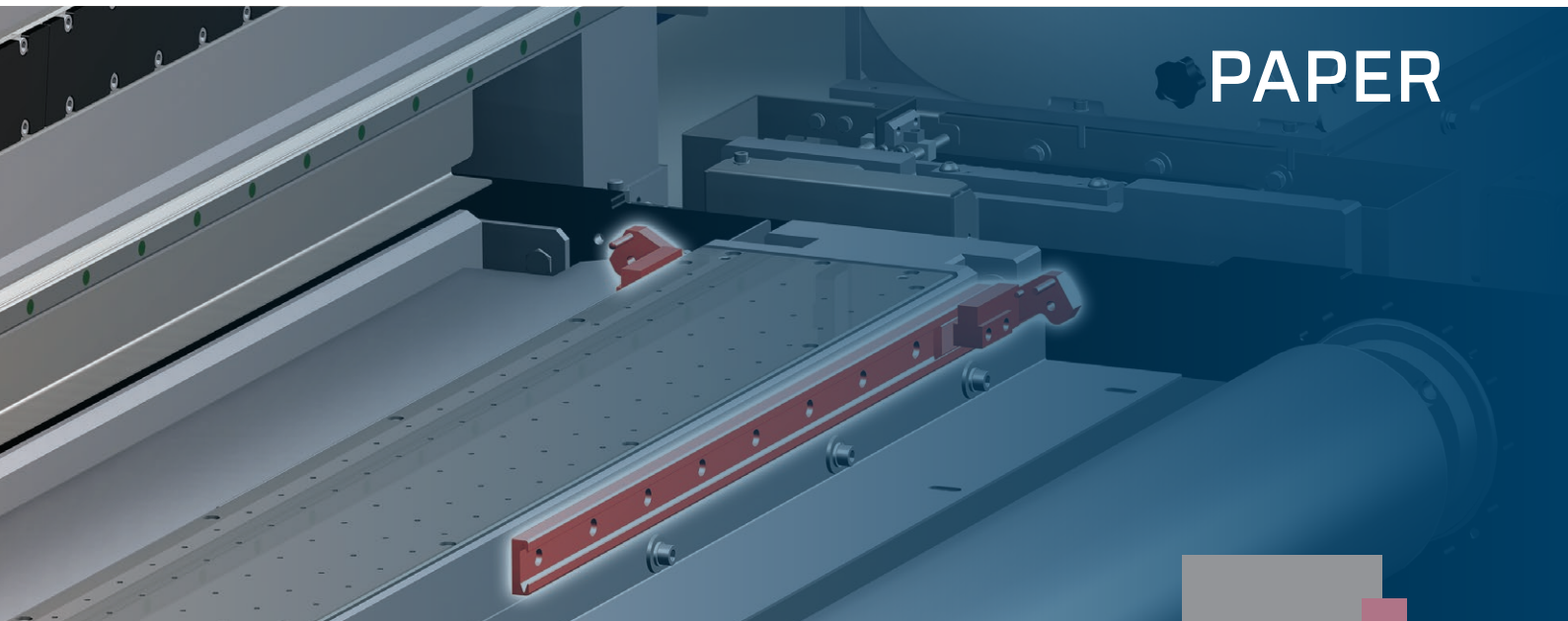

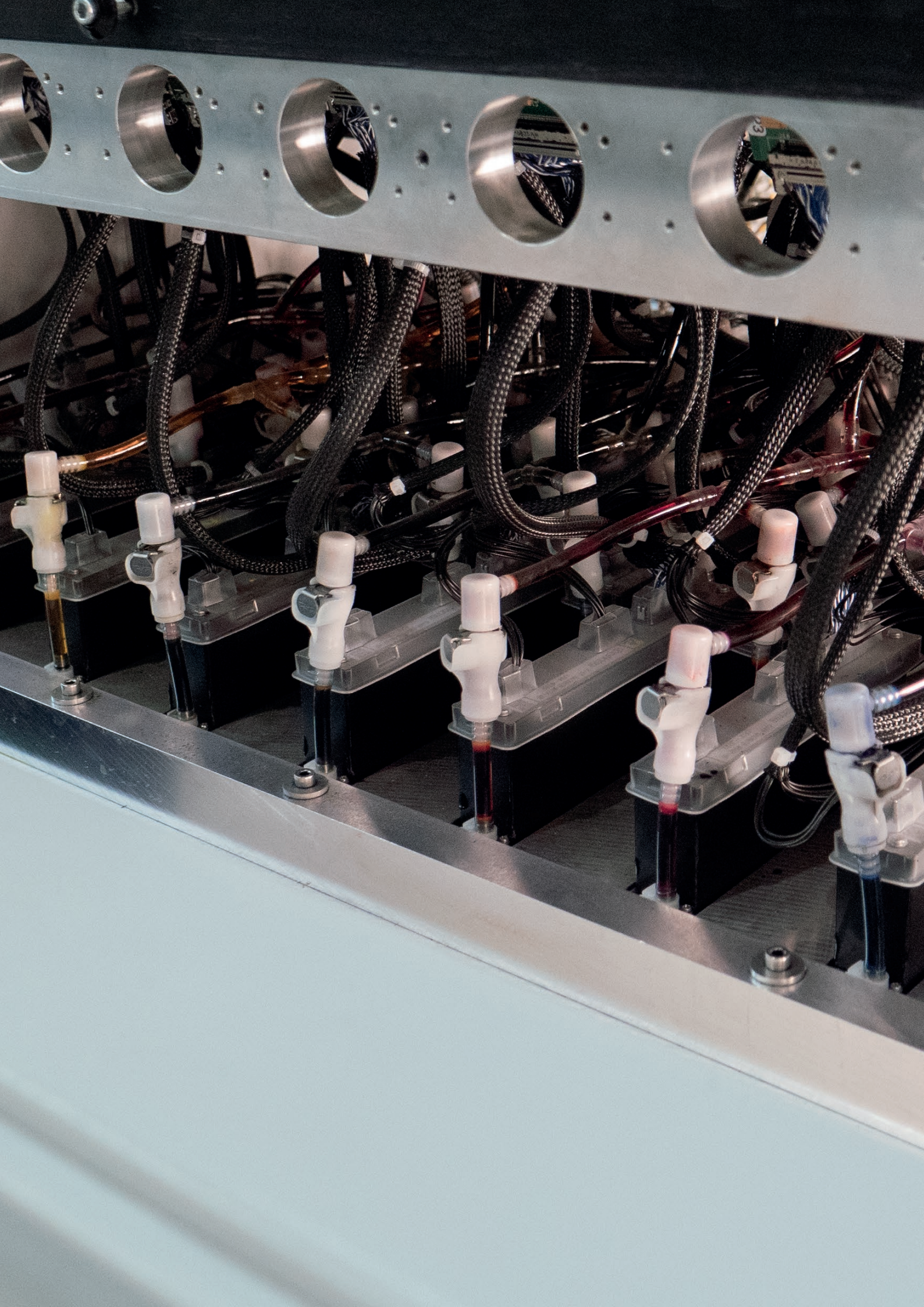



MS Printing Solutions

MS Printing Solution is a Dover Digital Printing company.

www.doverdigitalprinting.com

A long family history now reaching its 4th generation, full of experience and passion.

Tradition is very important for MS and with this deep knowledge of our industry, we strongly believe in the success of innovation.

The MS knowledge and experience allows us to develop innovative products for the demanding and ever-changing market of digital textile printing.

Our modern technologies allow us to improve any aspect of textile printing, starting from performance and up to including the important environmental issues.

The versatility of these digital technologies also opens the way to different printed applications such as paper and plastic substrates.

"The digital revolution is far more significant than the invention of writing or even of printing."

MS Printing Solution è una società del gruppo Dover.

www.doverdigitalprinting.com

Un percorso lungo quattro generazioni ricco di esperienza e di passione.

Per MS la tradizione è importante ed è proprio su questa consapevolezza che si deve ricercare il successo di un innovatore.

Sarebbe impossibile innovare senza conoscere profondamente le origini di un prodotto, la storia di un settore.

Le tecnologie moderne consentono di migliorare ogni aspetto della stampa: dalla performance produttiva alla sostenibilità ambientale.

La versatilità delle moderne tecnologie consente d'affacciarsi a numerosi settori oltre a quello tessile quali la carta e materiali plastici.

"La rivoluzione digitale è molto più rilevante dell'invenzione della scrittura e persino di quella della stampa."

MS Printing Solutions bir Dover Dijital Platformu şirketidir.

www.doverdigitalprinting.com

Uzun bir aile geçmişi büyük bir bilgi birikimi ve tutkuyla 4. nesline erişiyor.

Gelenek, MS için oldukça önemlidir ve bu derin bilgi birikimiyle, inovasyonun başarısına inanıyoruz.

MS bilgisi ve tecrübesi, sürekli değişen ve talepkar dijital tekstil pazarı için inovatif ürünler geliştirmemize olanak sağlıyor.

Modern teknolojilerimiz, performanstan başlayıp, önemli çevresel sorunlara kadar giden tekstil baskıya dair her türlü alanı geliştirmemize olanak sağlıyor.

Bu çok yönlü dijital teknolojiler aynı zamanda kağıt ve plastik alt katmanlar gibi farklı baskı uygulamalarına da yol açıyor.

"Dijital devrim, yazı ve hatta baskıdan çok daha büyük bir öneme sahiptir."

MS Printing Solutions 隶属于都福数码印花公司

www.doverdigitalprinting.com

其家族源远流长，现已达到第四代，充满了丰富的经验和激情。

传统对MS来说是非常重要的，我们对我们的行业有着深刻的了解，我们坚信创新的成功。

MS的知识和经验使我们能够为不断变化和高要求的数码纺织印花市场开发创新产品。

我们的现代技术使我们可以改进纺织品印花的任何方面，从性能到包括重要的环境问题。

这些数字技术的多功能性也为纸张和塑料基板等不同的印花应用开辟了道路。

数字化革命的意义远远超过书写的发明，甚至印刷的发明。





Index

6	Ink dust exhauster	11	Vacuum belt
7	Cold fixed pressure roll	12	Washing unit sponge group
7	Heated driven pressure roll	13	Jumbo roll
8	Unwinder carbon expandable shaft	14	Ø1000 mm unwinder/winder group
8	Winder carbon expandable shaft	14	Hot air blower
9	Brushes roll for winder	15	Power-D
9	8 Colors	16	Qwizard
10	Side guides	18	Machine configurations
11	Electrostatic bars		



Suitable for:

JP7 all paper

JPKevo all paper

Mini Lario



 ENG

INK DUST EXHAUSTER

System consisting of a vacuum cleaner, equipped with nozzles located on the printer, for extraction of ink powders that could be produced during printing.

 ITA

ASPIRATORE POLVERI DI INCHIOSTRO

Sistema composto da un aspiratore, dotato di bocchette dislocate sulla stampante, per l'estrazione delle polveri di inchiostro che potrebbero prodursi durante la stampa.

 TUR

MÜREKKEP TOZU EGZOZU

Yazdırma sırasında üretilebilecek mürekkep tozlarının çıkarılması için, yazıcıda bulunan memelerle donatılmış elektrikli süpürge den oluşan sistem.

 中文

墨尘吸尘器

系统中含有一个位于印刷机之上带有吸嘴的真空清洁吸尘器,用于提取打印之时可能产生的墨粉.

Suitable for:
JP7 all paper

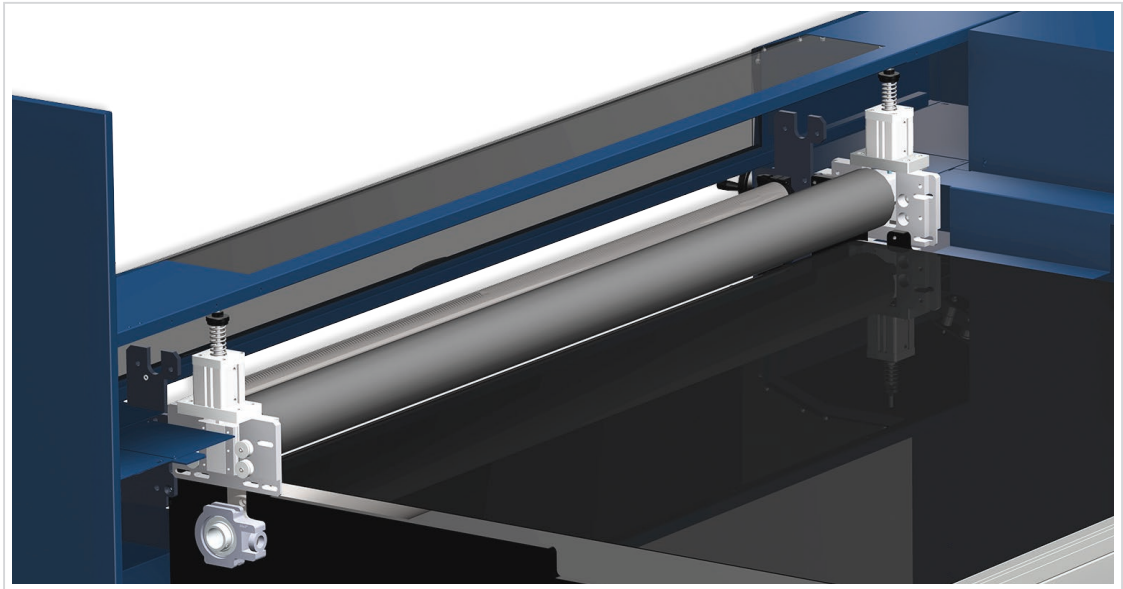

 ENG

COLD FIXED PRESSURE ROLL

A fixed cylinder that presses the media improving adherence to the printing belt.

 ITA

CILINDRO PRESSORE FISSO FREDDO

Cilindro fisso che premendo sul media consente di migliorarne l'adesione al tappeto da stampa.

 TUR

SOĞUK SABİT BASINÇ RULOSU

Baskı bandına yapışkanlığı arttıran ortamı bastıran sabit bir silindir.

 中文

冷固定压力辊

一个用来压住增加与印花导带间结合强度媒质的固定圆柱。

Suitable for:
JPKevo all paper
Mini Lario



 ENG

HEATED DRIVEN PRESSURE ROLL

Electrically heated roll, with mechanical handling that by pressing on the media improves adhesion to the printing mat.

 ITA

CILINDRO PRESSORE MOBILE RISCALDATO

Cilindro riscaldato elettricamente, dotato di movimentazione meccanica che premendo sul media consente di migliorarne l'adesione al tappeto da stampa.

 TUR

ISITMA SÜRÜCÜLÜ BASINÇ RULOSU

Mekanik elleçleme ile ortam üzerine bastırarak elektrikle ısıtılan rulo matbaaya yapışmayı artırır.

 中文

热驱动压力辊

电加热辊，带机械手柄，下压手柄提高媒体对印刷垫的附着力。

Suitable for:
JP4
JP4evo



ENG

UNWINDER CARBON EXPANDABLE SHAFT

Carbon version lighter and more rigid than the standard one.



ITA

ALBERO AD ESPANSIONE SVOLGITORE IN CARBONIO

Versione in carbonio più leggera e rigida di quella standard.



TUR

ÇÖZÜCÜ KARBON GENİŞLETİLEBİLİR ŞAFT

Karbon versiyonu standart olandan daha hafif ve daha serttir.



中文

碳纤维胀缩轴拆卷机

碳纤维版比标配更轻更坚固。

Suitable for:
JP4
JP4evo



ENG

WINDER CARBON EXPANDABLE SHAFT

Carbon version lighter and more rigid than the standard one.



ITA

ALBERO AD ESPANSIONE AVVOLGITORE IN CARBONIO

Versione in carbonio più leggera e rigida di quella standard.



TUR

SARICI KARBON GENİŞLETİLEBİLİR ŞAFT

Karbon versiyonu standart olandan daha hafif ve daha serttir.



中文

碳纤维胀缩轴卷绕机

碳纤维版比标配更轻更坚固。

Suitable for:
JP4
JP4evo



 ENG

BRUSHES ROLL FOR WINDER
Cylinder with bristles that flattens any waves of the paper.

 ITA

CILINDRO ALLARGATORE PER AVVOLGITORE
Cilindro dotato di setole che viene utilizzato per distendere le eventuali ondulazioni presenti sulla carta.

 TUR

YAYMA SİLİNDİRİ İÇİN SARMA CİHAZI
Kumaş dalgalarını düzleştiren fırça kıllı silindir.

 中文

抛掷滚筒
带有鬃毛的滚筒, 将织物张的所有波纹压平.

Suitable for:
JP4
JP4evo
JP7 all paper
JPKevo all paper
Mini Lario



 ENG

8 COLORS
The machine is equipped in such a way that it can handle 8 different colors or double four-color printing.

 ITA

8 COLORI
La macchina viene equipaggiata in modo tale che possa gestire 8 colori diversi oppure la doppia quadricromia.

 TUR

8 RENK
Makine, 8 farklı renk veya dörtlü dört renkli baskıyı karşılayacak şekilde donatılmıştır.

 中文

8 种颜色
机器可以进行8种不同颜色或双四色印刷.

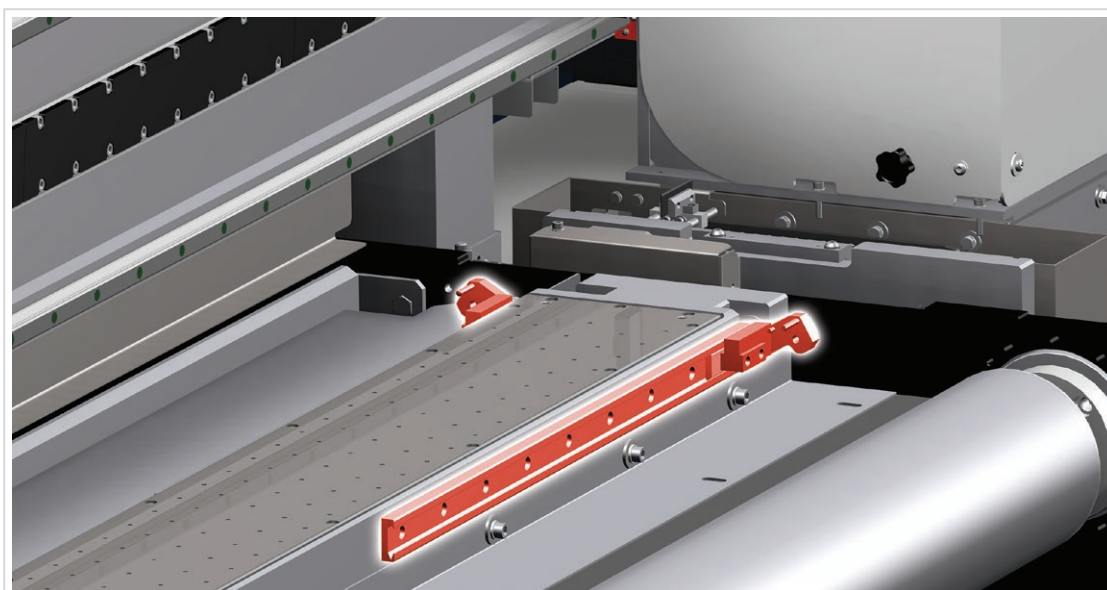

Suitable for:
JP4
JP4evo

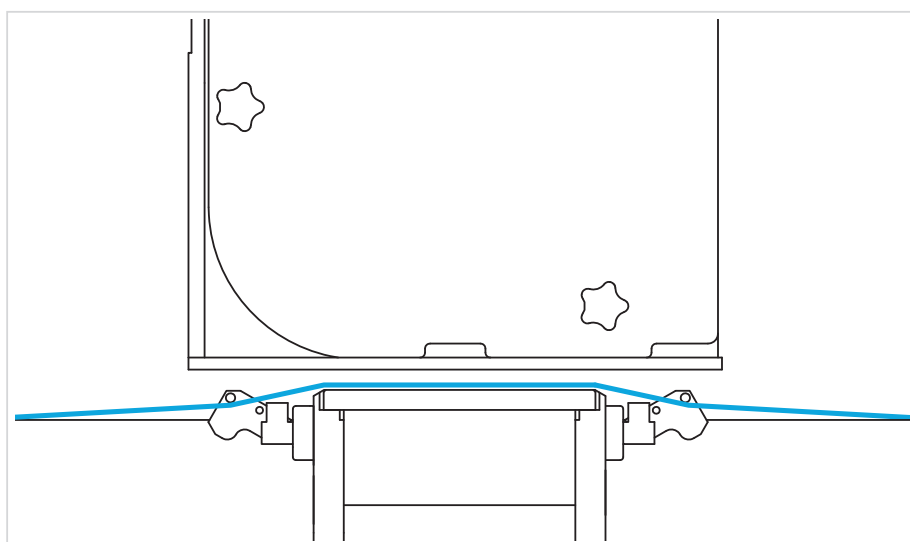

 ENG

SIDE GUIDES

A mechanical system that make the selvages on the media adhere on the printing surface.

 ITA

PREMI CIMOSSE

Sistema meccanico che permette di mantenere adese al piano stampa le cimosse presenti sul media.

 TUR

KUMAŞ KENARI PRESİ

Ortamdaki kumaş kenarlarını baskı yüzeyine yapıştıran mekanik bir sistem.

 中文

布边压机

将媒介上的布边贴在印花表面上的机械系统。

Suitable for:
JP7 all paper
JPKevo all paper

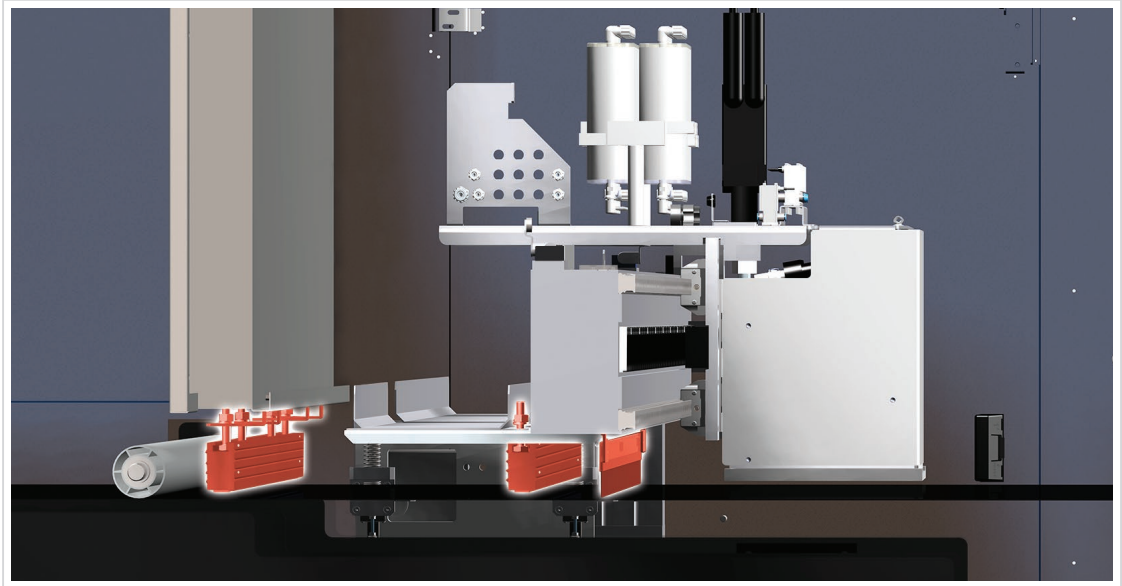

 ENG

ELECTROSTATIC BARS

Electrostatic bar unit that makes the paper stick to the printing belt.

 ITA

BARRE ELETTROSTATICHE

Sistema di Barre elettrostatiche che permette di far aderire la carta al tappeto da stampa.

 TUR

ELEKTROSTATİK ÇUBUKLAR

Kağıdı baskı bandına yapıştıracak elektrostatik bar birimi.

 中文

静电杆

将纸张贴在印花导带上的静电杆装置。

Suitable for:
Mini Lario

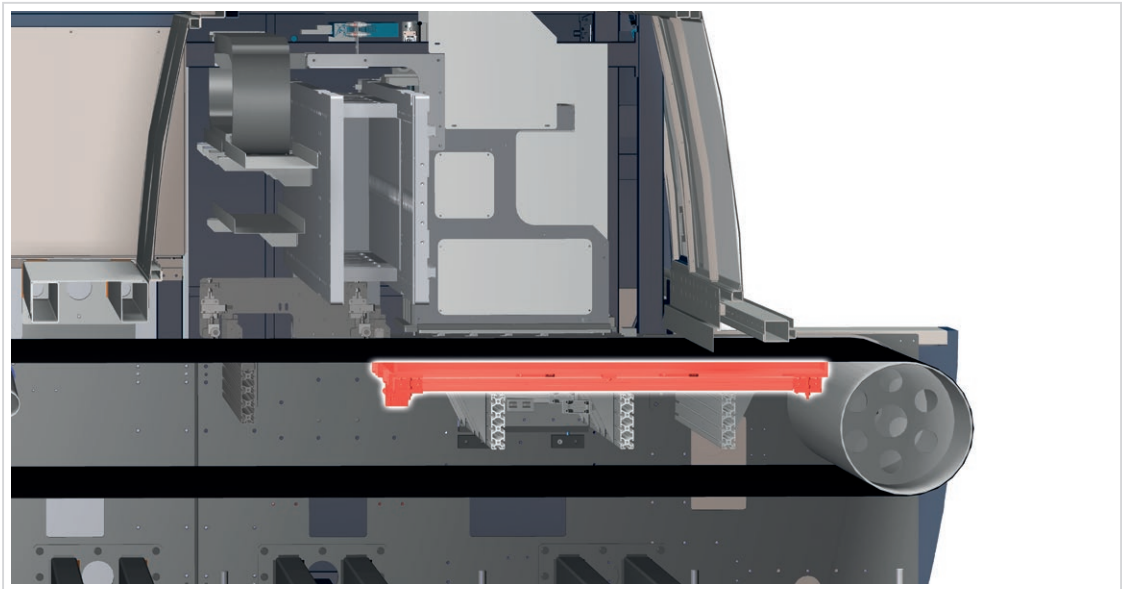

 ENG

VACUUM BELT

Belt with holes useful to allow air to pass through and to couple the media using the vacuum anchoring system, an alternative to traditional adhesive substances (glue coating). It consists of a series of vacuum tops divided into areas that can be enabled/disabled using manual valves.

 ITA

TAPPETO ASPIRANTE

Tappeto dotato di fori per permettere il passaggio dell'aria ed effettuare l'accoppiamento del media sfruttando l'ancoraggio a depressione, alternativa alle sostanze adesive tradizionali (resinatura). È costituito da una serie di piani aspiranti suddivisi in aree che si possono abilitare/disabilitare tramite valvole manuali.

 TUR

VAKUM KAYIŞI

Geleneksel yapışkan maddelere (yapıştırıcı kaplama) alternatif olarak, havanın geçmesine izin vermek ve vakum bağlama sistemleri kullanılarak medyayı birleştirmek için kullanışlı deliklere sahip bir kayıştır. Manuel valfler kullanılarak etkinleştirilebilen/devre dışı bırakılabilen alanlara bölünmüş bir dizi vakum üstünden oluşur.

 中文

真空带

允许空气通过的多孔皮带，使用真空锚固系统耦合介质，用于替代传统的粘合剂物质（胶涂层）。它由一系列分成多个区域的真空顶层组成，这些区域可以手动启用或禁用。

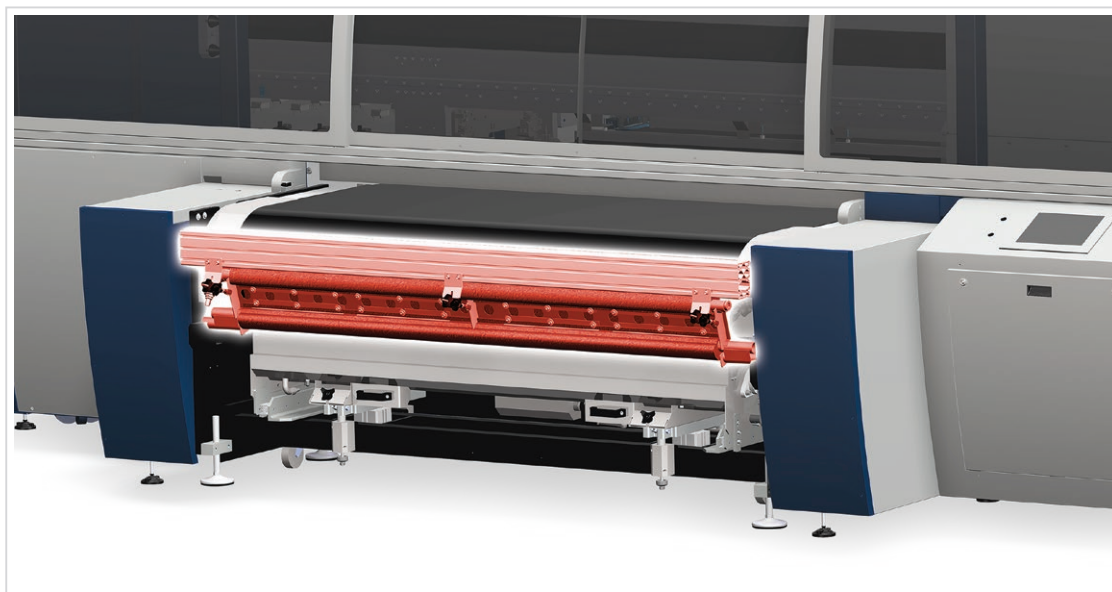

Suitable for:
Mini Lario

 ENG

WASHING UNIT SPONGE GROUP

Adjustable sponge, positioned at the entrance of the washing system. It increases the ability to remove impurities on the printing belt.

 ITA

GRUPPO SPUGNA PER LAVAGGIO

Spugna regolabile, posizionata in ingresso al sistema di lavaggio, permette di aumentarne la capacità di rimozione delle impurità presenti sul tappeto di stampa.

 TUR

YIKAMA ÜNİTESİ SÜNGER GRUBU

Ayarlanabilir sünger, yıkama sisteminin girişine yerleştirilir. Yazdırma bandındaki yabancı maddeleri atma kabiliyetini artırır.

 中文

清洗机海绵组织

可调节海绵, 位于清洗系统入口处. 提高了去除印花导带上杂质的能力.



Suitable for:

JP7 all paper

JPKevo all paper

Mini Lario

 ENG

JUMBO ROLL

It consists of an unwinder and a winder for paper rolls. The winder is equipped with a special centring system that compensates for any shifts in the paper while keeping it in the correct position during roll formation. It can be equipped with:

BRUSHES ROLL

Cylinder with bristles that flattens any waves of the paper.

 ITA

JUMBO ROLL

È formato da uno svolgitoro ed un avvolgitoro per bobine di carta. L'avvolgitoro è dotato di un apposito sistema centratore che compensa eventuali spostamenti della carta mantenendola nella posizione corretta durante la formazione della bobina. Può essere accessorizzato con:

CILINDRO ALLARGATORE

Cilindro dotato di setole che permette di distendere le eventuali ondulazioni presenti sulla carta.

 TUR

JUMBO ROLL

Kağıt silindirleri için bir rulo açıcı ve bir sarıcıdan oluşur. Rulo sarıcı, rulo oluşumu sırasında doğru pozisyonda kalırken kağıttaki herhangi bir kaymayı dengeleyen özel bir merkezleme sistemi ile donatılmıştır. Şununla yapılandırılabilir:

YAYMA SİLİNDİRİ

Kağıdın dalgalarını düzleştiren fırça kıllı silindir.

 中文

JUMBO ROLL

由用于卷筒纸的一个退绕机和一个收卷机组成。收卷机装有一个特殊的对中系统，可以在成卷期间补偿纸张的任何横移，同时将纸张固定在正确的位置上。

可配备有：

抛掷滚筒

带有鬃毛的滚筒，将织物张的所有波纹压平。

Suitable for:
JP4
JP4evo

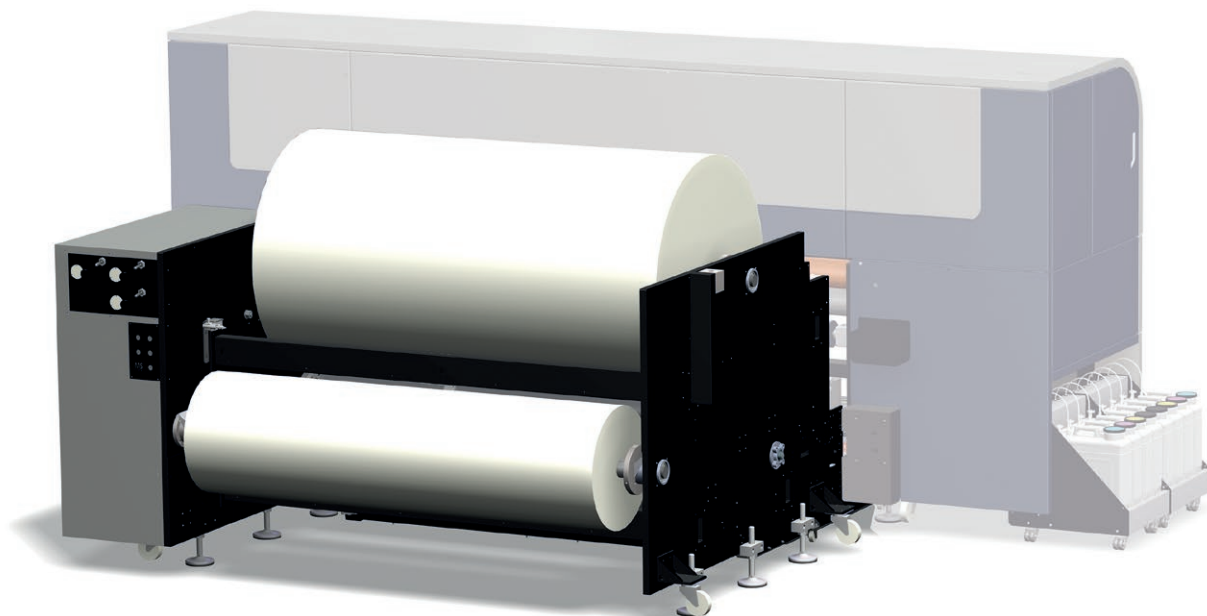

 ENG

Ø1000 mm UNWINDER/WINDER GROUP

It consists of an unwinder able to handle rolls of up to 1000 mm diameter and of a winder able to handle rolls of up to 500 mm diameter.

 ITA

GRUPPO SVOLGITORE/AVVOLGITORE Ø1000 mm

È formato da uno svolgitore in grado di gestire bobine fino a 1000 mm di diametro e da un avvolgitore in grado di gestire bobine fino a 500 mm di diametro.

 TUR

Ø1000 mm ÇÖZÜCÜ/SARICI GRUBU

Çapı 1000 mm'ye kadar ruloları tutabilen bir açıcı ve çapı 500 mm'ye kadar ruloları tutabilen bir sarıcıdan oluşur.

 中文

Ø1000 mm 拆卷机/卷绕机组

由一台能处理直径高达1000 mm布卷的拆卷机及一台能处理直径高达500 mm布卷的卷绕机组组成。

Suitable for:
JP4
JP4evo



 ENG

HOT AIR BLOWER

It is a compact electric dryer that integrates within the printers, enabling to print, dry and rewind without increasing machine dimensions.

 ITA

SOFFIERIA ARIA CALDA

È un asciugatoio elettrico compatto che si integra all'interno delle stampanti permettendo così di stampare, asciugare e riavvolgere senza aumentare gli ingombri macchina.

 TUR

SICAK HAVA FANI

Yazıcılar içinde entegre bir kompakt elektrikli kurutucu, makinenin boyutlarını arttırmaksızın yazdırabilmeyi, kurutabilmeyi ve tekrar sarabilmeyi sağlar.

 中文

热风机

这是一台整合在打印机内的紧凑型吹风机，使得在不增加机器外形尺寸的情况下可以打印、干燥和复卷。



Suitable for:

JP7 all paper

JPKevo all paper

Mini Lario

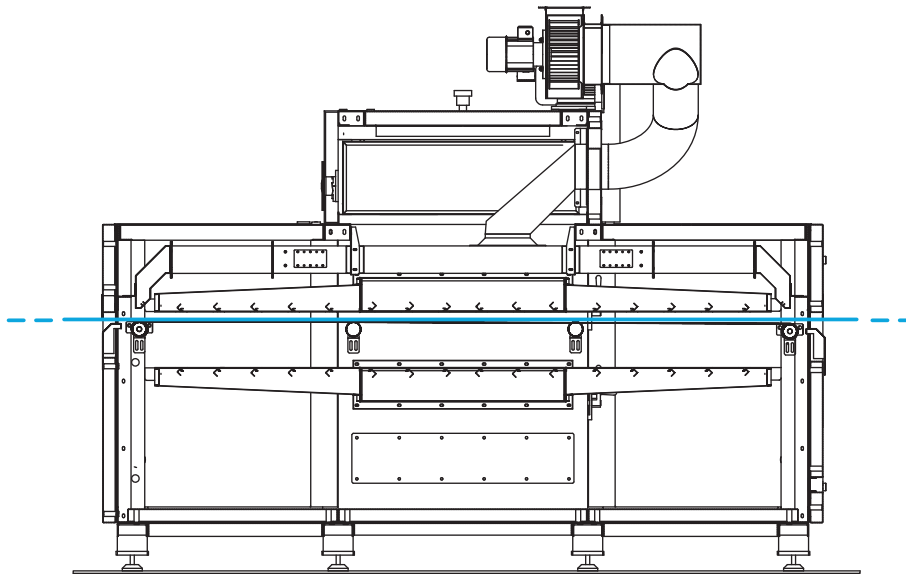

 ENG

POWER-D

Dryer equipped with a chamber where hot air jets are introduced for drying the media after printing.

 ITA

POWER-D

Asciugatoio dotato di una camera in cui vengono immessi getti di aria calda per consentire l'operazione di asciugatura del media dopo la stampa.

 TUR

POWER-D

Kurutucu, baskı sonrasında ortamı kurutmak için sıcak hava püskürtülerinin uygulandığı bir bölme ile donatılmıştır.

 中文

POWER-D

带有一个引入热气流以便在印刷之后烘干媒介腔室的干燥机。

Qwizard

Suitable for:

JP4

JP4evo

JP7 all paper

JPKevo all paper

Mini Lario



 ENG

Qwizard

Qwizard was developed with the aim of freeing the staff working on the printer from drawing management, enabling it to focus on machine management. With few, simple, and intuitive steps, you can place your prints by avoiding mistakes and long waiting times for data preparation.

 ITA

Qwizard

Qwizard nasce con l'obiettivo di liberare il personale che opera sulla stampante dalla gestione dei disegni permettendogli di concentrarsi sulla gestione della macchina. Con pochi, semplici, ed intuitivi passaggi è possibile disporre la stampa evitando errori e lunghe attese di preparazione dati.

 TUR

Qwizard

Qwizard, yazıcıda çalışan personelin çizim yönetiminden kurtulması amacıyla geliştirildi ve makine yönetimine odaklanmıştır. Az, basit ve sezgisel adımlarla, verilerinizi hazırlama hatalarını ve uzun bekleme sürelerini önleyerek çıktılarınızı yerleştirebilirsiniz.

 中文

Qwizard

Qwizard 的开发旨在将打印机操作人员从图纸管理工作中解脱出来,使其能专注于设备管理。通过几个简单直观的步骤,您就可以完成印刷,无须担心出错,也不需要作冗长的数据准备工作。

Job queue	View as	Layout	Selected print mode	Direction	Copies	Source Images	View as
Queued	Large icons	MIS Qwizard	D: 4passes 9levels StdSpeed	Uni	1	Recent	Large icons
Active job		cm 0 10 20 30 40 50 60 70 80 90 100 110 120 130 140 150 160 170				<ul style="list-style-type: none"> tessile fiori masse.xpf+tessile fiori masse.xpf+tessile fi JP4 D2: 4passes 9levels FastSpeed - Uni 10/05/17 10:20 - Size: 604 x 538 mm 	
<ul style="list-style-type: none"> 1335031_yPLANES_4.tif JP4 D2: 4passes 9levels FastSpeed - Uni 22/05/17 09:18 - Size: 635 x 508 mm 						<ul style="list-style-type: none"> tessile masse variantato.xpf JP4 D2: 4passes 9levels FastSpeed - Uni 12/05/17 08:30 - Size: 200 x 200 mm 	
<ul style="list-style-type: none"> 2142579_rFarmersMarket-CVH.tif JP4 D: 4passes 9levels StdSpeed - Uni 19/05/17 16:38 - Size: 600 x 738 mm 						<ul style="list-style-type: none"> 2142579_rFarmersMarket-CVH.tif JP4 D2: 4passes 9levels FastSpeed - Uni 12/05/17 08:22 - Size: 600 x 738 mm 	
<ul style="list-style-type: none"> astratto.tif JP4 D: 4passes 9levels StdSpeed - Uni 19/05/17 16:38 - Size: 500 x 835 mm 						<ul style="list-style-type: none"> astratto.tif JP4 D2: 4passes 9levels FastSpeed - Uni 15/05/17 08:50 - Size: 500 x 835 mm 	
<ul style="list-style-type: none"> 6734 AN R9 var 2 green.tif JP4 D: 4passes 9levels StdSpeed - Uni 19/05/17 16:38 - Size: 733 x 1043 mm 						<ul style="list-style-type: none"> 6734 AN R9 var 2 green.tif JP4 D2: 4passes 9levels FastSpeed - Uni 15/05/17 08:50 - Size: 733 x 1043 mm 	
<ul style="list-style-type: none"> 2142579_rFarmersMarket-CVH.tif JP4 D: 4passes 9levels StdSpeed - Uni 19/05/17 17:21 - Size: 600 x 738 mm 						<ul style="list-style-type: none"> fiori viola.xpf+fiori viola.xpf+fiori viola.xpf+fiori viola.xp JP4 D2: 4passes 9levels FastSpeed - Uni 15/05/17 08:50 - Size: 1230 x 450 mm 	
<ul style="list-style-type: none"> 6734 AN R9 var 2 green.tif JP4 D: 4passes 9levels StdSpeed - Uni 19/05/17 17:21 - Size: 733 x 1043 mm 						<ul style="list-style-type: none"> tessile masse variantato.xpf JP4 D2: 4passes 9levels FastSpeed - Uni 15/05/17 08:50 - Size: 200 x 200 mm 	

Qwizard



ENG

What Qwizard does

User friendly	Interface with touchscreen technology with very little learning time.
Optimization	Thanks to its simple operation, the operator can easily position drawings in the print area by optimizing space and productivity.
Performance	The data processed by the print RIP are stored directly in the Qwizard, ensuring the maximum productivity of the printer for all available modes, thus avoiding slowdowns due to the slowness of the drawing software.
Automation	Files are sent from the drawing Studio already prepared with the correct calibration and print modes to prevent any mistakes of the operator in preparing the prints.
Control	You can filter the production according to media, print mode, or color calibration.
Archiving	Thanks to a tremendous memory capacity, modern data management, data compression and distribution technologies, Qwizard can store thousands of drawings and layouts produced.
Compatibility	Qwizard was developed to be applied to all MS printers for all sectors where they work: textile, transfer, soft signage.



ITA

Cosa offre Qwizard

User friendly	Interfaccia con tecnologia touchscreen con tempo di apprendimento ridottissimo.
Ottimizzazione	Grazie alla semplicità d'uso l'operatore può facilmente posizionare i disegni nell'area di stampa ottimizzando lo spazio utilizzato e la produttività.
Performance	I dati elaborati dal RIP di stampa sono memorizzati direttamente nel Qwizard garantendo la massima produttività della stampante per tutte le modalità disponibili, evitando così rallentamenti dovuti alla lentezza dei software di elaborazione disegni.
Automazione	I file vengono inviati dallo Studio disegni già predisposti con le giuste calibrizioni e modalità di stampa così da impedire eventuali errori dell'operatore nella predisposizione delle stampe.
Controllo	È possibile filtrare la produzione in base al media, alle modalità di stampa o alle calibrizioni colore.
Archiviazione	Grazie ad una notevole capacità di memoria, a moderne tecnologie di gestione, compressione e distribuzione dei dati, Qwizard è in grado di memorizzare migliaia di disegni e layout prodotti.
Compatibilità	Qwizard nasce per poter essere applicato a tutte le stampanti MS per tutti i settori in cui esse operano: tessile, transfer, soft signage.



TUR

Qwizard ne yapar

Kullanıcı dostudur	Çok az öğrenme süresi ile dokunmatik ekran teknolojisine sahip arayüz.
Optimizasyon	Basit şekilde çalışması sayesinde, operatör alan ve üretkenliği optimize ederek çizimleri baskı alanında kolaylıkla konumlandırabilir.
Performans	Baskı RIP'si tarafından işlenen veriler doğrudan Qwizard'a depolanarak yazıcının tüm mevcut modları için maksimum üretkenliği sağlanmış olur, böylece yavaş çizim yazılımı nedeniyle yavaşlamalar önlenir.
Otomasyon	Dosyalar, operatörün baskıları hazırlamadaki hatalarını önlemek için doğru kalibrasyon ve baskı modlarıyla hazırlanarak çizimi yapılan Stüdyodan gönderilir.
Kontrol	Üretimi, ortama, baskı moduna veya renk kalibrasyonuna göre filtreleyebilirsiniz.
Arşivleme	Qwizard, muazzam bellek kapasitesi, modern veri yönetimi, veri sıkıştırma ve dağıtım teknolojileri sayesinde binlerce çizim ve mizanpajı üretebilir.
Uygunluk	Qwizard, çalıştıkları tüm sektörler için tüm MS yazıcılarına uygulanmak üzere geliştirildi: tekstil, transfer, hafif tabela.









中文

Qwizard 的作用

操作简便	触屏技术界面，简单易懂，一学就会。
最优化	由于操作简便，操作人员可以很容易在打印区域内进行图片定位，优化空间利用，提高生产效率。
性能	经打印RIP处理的数据被直接存储在Qwizard内，使打印机的生产效率在任何可用模式下均能发挥其最大潜力，从而避免受到缓慢的绘图软件拖累。
自动化	Studio绘图软件发送的文件已经正确校准和打印模式的制备，避免了操作人员在准备图片时发生错误。
控制	您可以根据媒体，打印模式或颜色校准对生产进行筛选。
存档	由于拥有巨大的内存容量，现代化的数据管理，数据压缩和分配技术，Qwizard能够存储成千上万张图片及生成的图版。
兼容性	Qwizard已开发适用于所有部门应用的各种MS打印机：纺织，转印，软标等。

Machine configurations

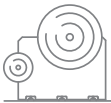
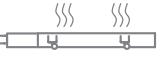
n°opt.	JP4 - JP4evo		Possible configurations / Configurazioni possibili	
			1 (HS=1800 to 2200 mm)	2 (HS=2400 to 3200 mm)
Printers - Stampante - Yazıcı - 打印机				
4		Unwinder carbon expandable shaft Albero ad espansione svolgitore in carbonio Çözücü karbon genişletilebilir şaft 碳纤维胀缩轴拆卷机	-	<input type="checkbox"/>
5		Winder carbon expandable shaft Albero ad espansione avvolgitore in carbonio Sarici karbon genişletilebilir şaft 碳纤维胀缩轴卷绕机	-	<input type="checkbox"/>
6		Brushes roll for winder Cilindro allargatore per avvolgitore Yayma silindiri için sarma cihazı 抛掷滚筒	<input type="checkbox"/>	<input checked="" type="checkbox"/>
7		8 Colors 8 Colori 8 Renk 8 种颜色	<input type="checkbox"/>	<input type="checkbox"/>
8		Side guide Premi cimosse Kumaş kenarı presi 抛掷滚筒 收卷	<input type="checkbox"/>	<input checked="" type="checkbox"/>
16		Qwizard	<input type="checkbox"/>	<input type="checkbox"/>
Unwinder/Winder - Svolgitore/Avvolgitore - Açma Cihazı/Sarma Cihazı - 退绕机/收卷机				
13		Ø1000 mm unwinder/winder group Gruppo svolgitore/avvolgitore Ø1000 mm Ø1000 mm çözücü/sarici grubu Ø1000 mm 拆卷机/卷绕机组	<input type="checkbox"/>	-
Dryers - Asciugatoio - Kurutucu - 干燥机				
14		Hot air blower Soffieria aria calda Sıcak hava fani 热风机	<input checked="" type="checkbox"/>	<input checked="" type="checkbox"/>

= Supplied as standard / Fornito di serie
Standart olarak tedarik edilir / 标准配置

= Optional

a = Cannot be supplied individually / Non può essere fornito singolarmente
Ayrı olarak tedarik edilmez / 不能单独供应

n°opt.	JP7 all paper		Possible configurations / Configurazioni possibili Olası yapılandırmalar / 可能的配置
Printers - Stampante - Yazıcı - 打印机			
1		Ink dust exhauster Aspiratore polveri di inchiostro Mürekkep tozu egzozu 墨尘吸尘器	<input type="checkbox"/>
2		Cold fixed pressure roll Cilindro pressore fisso freddo Soğuk sabit basınç rulosu 冷固定压力辊	<input checked="" type="checkbox"/>
7		8 Colors 8 Colori 8 Renk 8 种颜色	<input checked="" type="checkbox"/>
9		Electrostatic bars Barre elettrostatiche Elektrostatik çubuklar 静电杆	<input type="checkbox"/>
16		Qwizard	<input type="checkbox"/>
Unwinder/Winder - Svolgitore/Avvolgitore - Açma Cihazı/Sarma Cihazı - 退绕机/收卷机			
12		Jumbo Roll	<input type="checkbox"/>
		Optional for Unwinder/Winder Brushes roll Cilindro allargatore Yayma silindiri 抛掷滚筒	<input type="checkbox"/> (a)
Dryers - Asciugatoio - Kurutucu - 干燥机			
15		Power-D	<input type="checkbox"/>

= Supplied as standard / Fornito di serie
Standart olarak tedarik edilir / 标准配置

= Optional

a = Cannot be supplied individually / Non può essere fornito singolarmente
Ayrı olarak tedarik edilmez / 不能单独供应

JPKevo all paper

Possible configurations / Configurazioni possibili
Olası yapılandırmalar / 可能的配置

n°opt.

1

Printers - Stampante - Yazıcı - 打印机

1		Ink dust exhauster Aspiratore polveri di inchiostro Mürekkep tozu egzozu 墨尘吸尘器	<input type="checkbox"/>
---	---	---	--------------------------

3		Heated driven pressure roll Cilindro pressore mobile riscaldato Isitma sürücü basıncı rulosu 热驱动压力辊	<input checked="" type="checkbox"/>
---	---	--	-------------------------------------

7		8 Colors 8 Colori 8 Renk 8 种颜色	<input checked="" type="checkbox"/>
---	---	---	-------------------------------------

9		Electrostatic bars Barre elettrostatiche Elektrostatik çubuklar 静电杆	<input type="checkbox"/>
---	---	--	--------------------------

16		Qwizard	<input type="checkbox"/>
----	---	---------	--------------------------

Unwinder/Winder - Svolgitore/Avvolgitore - Açma Cihazı/Sarma Cihazı - 退绕机/收卷机

12		Jumbo Roll	<input type="checkbox"/>
----	--	------------	--------------------------

Optional for Unwinder/Winder

		Brushes roll Cilindro allargatore Yayma silindiri 抛掷滚筒	<input type="checkbox"/> (a)
--	---	---	------------------------------

Dryers - Asciugatoio - Kurutucu - 干燥机

15		Power-D	<input type="checkbox"/>
----	---	---------	--------------------------

= Supplied as standard / Fornito di serie
Standart olarak tedarik edilir / 标准配置

= Optional

a = Cannot be supplied individually / Non può essere fornito singolarmente
Ayrı olarak tedarik edilmez / 不能单独供应

n°opt.	Mini Lario		Possible configurations / Configurazioni possibili Olası yapılandırmalar / 可能的配置
Printers - Stampante - Yazıcı - 打印机			
1		Ink dust exhauster Aspiratore polveri di inchiostro Mürekkep tozu egzozu 墨尘吸尘器	<input type="checkbox"/>
3		Heated driven pressure roll Cilindro pressore mobile riscaldato Isitma sürücü basıncı rulosu 热驱动压力辊	<input checked="" type="checkbox"/>
7		8 Colors 8 Colori 8 Renk 8 种颜色	<input checked="" type="checkbox"/>
10		Vacuum belt Tappeto aspirante Vakum kayışı 真空带	<input type="checkbox"/>
11		Washing unit sponge group Gruppo spugna per lavaggio Yıkama ünitesi sünger grubu 清洗机海绵组织	<input checked="" type="checkbox"/>
16		Qwizard	<input checked="" type="checkbox"/>
Unwinder/Winder - Svolgitore/Avvolgitore - Açma Cihazı/Sarma Cihazı - 退绕机/收卷机			
12		Jumbo Roll	<input type="checkbox"/>
		Optional for Unwinder/Winder Brushes roll Cilindro allargatore Yayma silindiri 抛掷滚筒	<input type="checkbox"/> (a)
Dryers - Asciugatoio - Kurutucu - 干燥机			
15		Power-D	<input type="checkbox"/>

= Supplied as standard / Fornito di serie
Standart olarak tedarik edilir / 标准配置

= Optional

a = Cannot be supplied individually / Non può essere fornito singolarmente
Ayrı olarak tedarik edilmez / 不能单独供应



The contents of this guide may be changed without notice. Nothing contained in this publication should be construed as a modification or declaration of the terms of any purchase agreement.

Il contenuto di questa guida può essere modificato senza preavviso. Nulla di quanto contenuto nella presente pubblicazione può inoltre essere interpretato come modifica o asserzione dei termini di qualsivoglia contratto di acquisto.

Bu kılavuzun içindekiler haber verilmeksizin deęiştirilebilir. Ayrıca, bu yayında yer alan şeylerin hiçbirini herhangi bir satın alma sözleşmesinin deęiştirilmesi veya ilanı olarak yorumlanamaz.

本公司可能对本说明书内容进行修改，恕不另行通知。本出版物中所含任何内容均不得被视为对任何买卖合同条款的修订或书面声明。

